

CONCEPT MODELS

Web Address: <http://www.con-sys.com>

8331 Sheep Ranch Rd.
Mountain Ranch, CA 95246

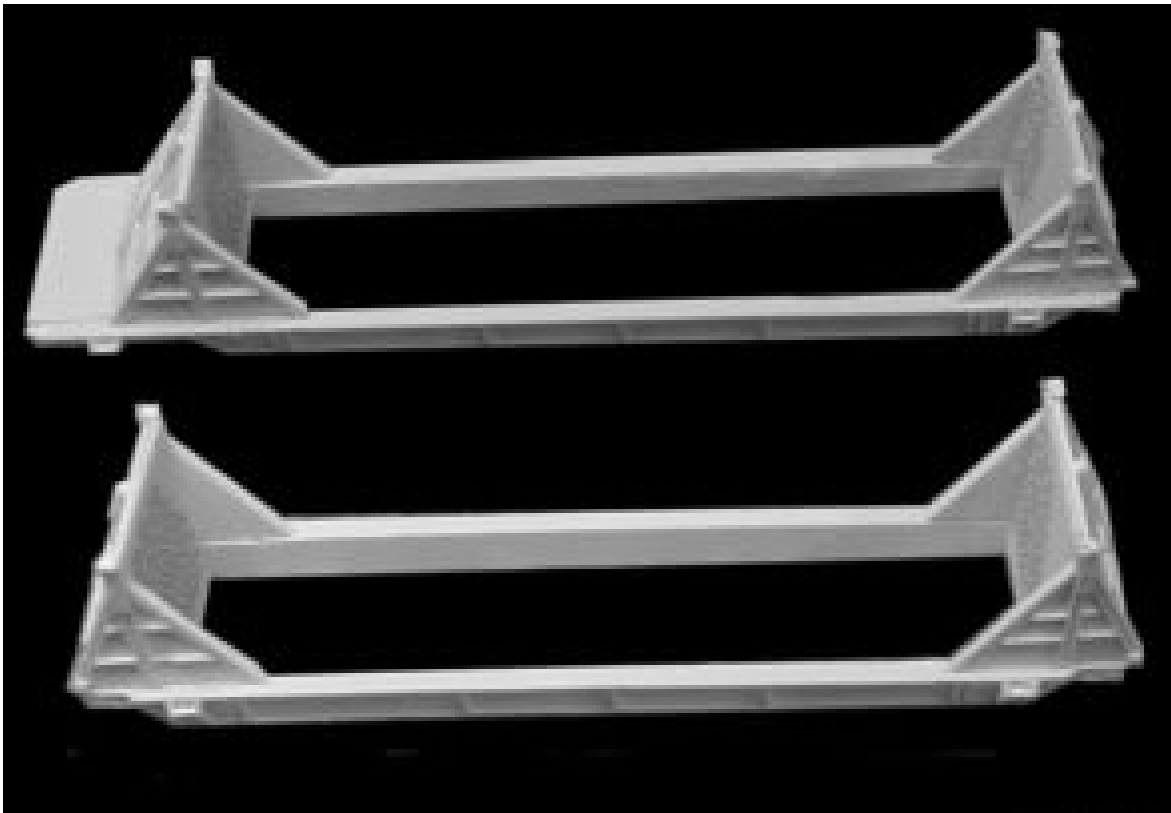

**SP DOUBLE STACK CONTAINER
CARS INSTRUCTIONS**

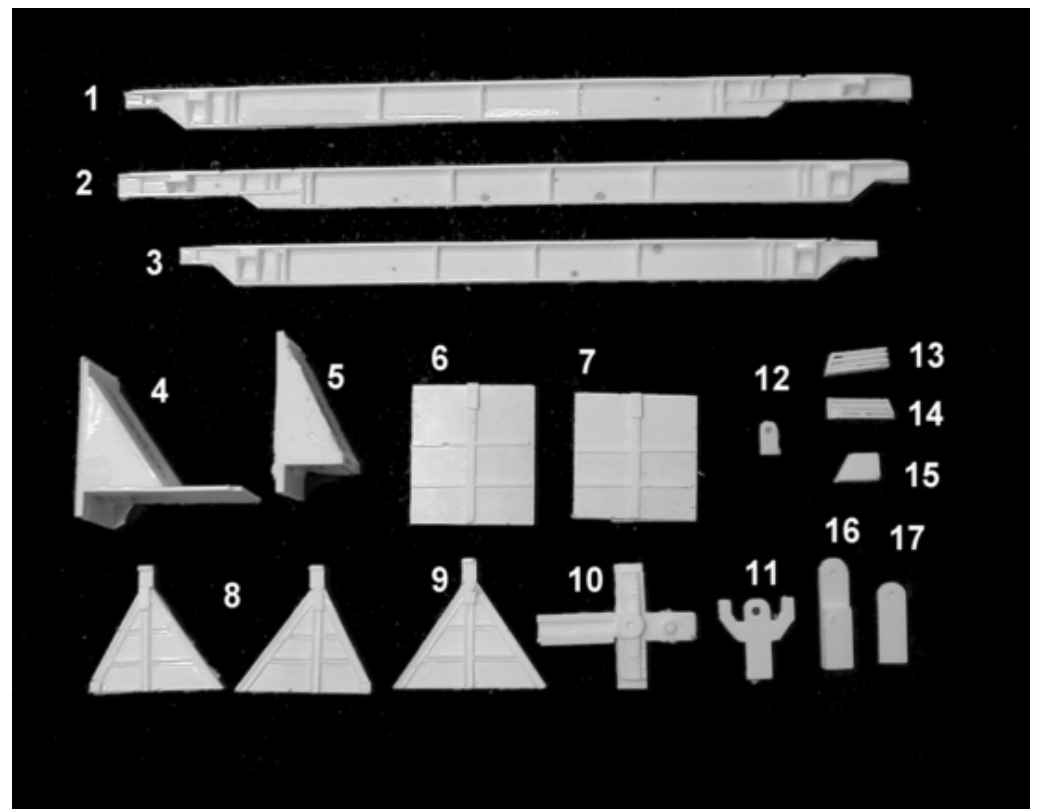
PARTS

Item No.	PART NO.	DESCRIPTION	QTY.
1	3000-1	End Unit – Left Sill	2
2	3000-2	End Unit – Right Sill	2
3	3000-3	Intermediate Unit Sill	8
4	3000-4	End Unit Weight	2
5	3000-5	Short End Weight	8
6	3000-6	End Unit Fascia	2
7	3000-7	Short End Fascia	10
8	3000-8	Short End Side (pr)	10
9	3000-9	End Unit sides	4
10	3000-10	End Sill/Coupler Mount	2
11	3000-11	Coupling	16
12	3000-12	Lift Ring – Ends	4
13	3000-13	Adapter Channel Left	10
14	3000-14	Adapter Channel Right	10

Item No.	DESCRIPTION	QTY.
15	Adapter Arm Support	20
16	Male Coupling	4
17	Female Coupling	4
18	Center Supports - .080" x .188" x 9 s.f.	10
19	End Supports - .080" x .250" x 9 s.f.	10
20	Coupler Covers	2
21	1/8" x 2-56 Mach. Screws	2
22	1/2" x 2-56 Mach. Screws	4
23	3/8" x 2-56 Mach. Screws	2
24	Truck Spacers for 1/8" hole	4
25	Brake Reservoir Tank	3
26	Brake Valve	3
27	Decals – set	1
28	Instructions	1

Tools

All basic model workers tools – files, motor-tool with fine burrs, hobby knife, 1/8” drill, clamps, Wood blocks for holding parts square, metal square, etc. You will also need to purchase netting to simulate the chain link bottom on the car from any yard goods supply.

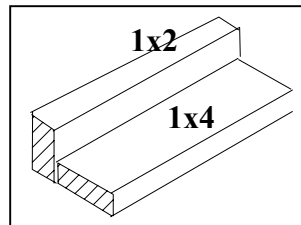

A gluing fixture is a great aid to assembly. It helps hold parts square while gluing.

NOTE: This kit consists of resin castings and must be assembled with an ACC cement (not provided) – both the thicker types as well as the thin. Solvent cements will **NOT** bond the parts together! Resin parts are more fragile than common styrene plastic used in injection molded models. Use reasonable care in handling and do not apply any solvents. The illustrations at the front show the general layout of parts for the car. Work very carefully when positioning the parts for gluing. ACC cements adhere very quickly and permanently.

Gluing with ACC Cements – USE WITH CARE

ACC cements allow the modeler to work very quickly. A general rule is to use the thin cements to glue long joints taking advantage of capillary action that makes the cement run the length of the seam. The thicker cement is suited to applying large area parts to each other. An accelerator can be applied sparingly. One technique is to apply the glue to one part and the accelerator to the other part to be joined. I also use a Q-tip to apply a minute amount of accelerator to the glue after the parts have been joined. The accelerator triggers the ACC cement to set very quickly. It is only slightly slower with the thicker cement.

WARNING

Some parts have lead encapsulated within them. In the event the lead is exposed for any reason, do not allow it to remain on the skin. Dispose of any lead shavings that may result. Obey all safety precautions of all suggested cements and assembly materials.

PAINTING Wash the parts before assembling with a dish washing detergent such as “Dawn”. Rub lightly with a soft sponge. Use a lacquer based primer such as floquil.

ASSEMBLY

1 Attach the End Unit Side Sills (1,2) to the End Unit Weight (4) as shown.

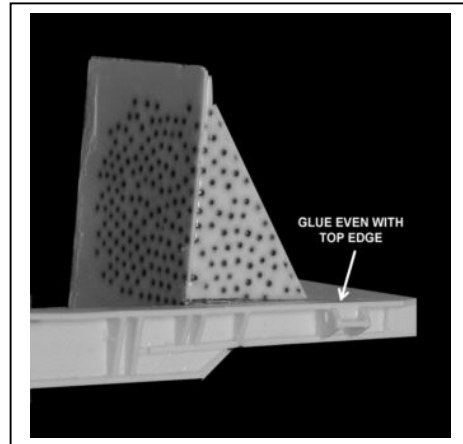

2 Attach the short end of the End Unit Sills as shown to a Short end Weight (5) as shown.

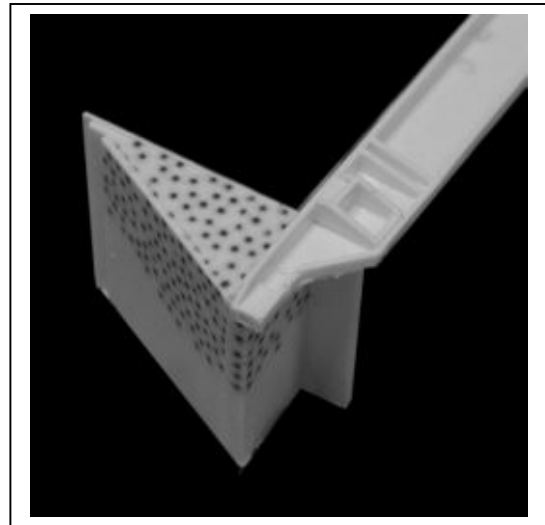

3 Complete the assembly by attaching the other sill as shown

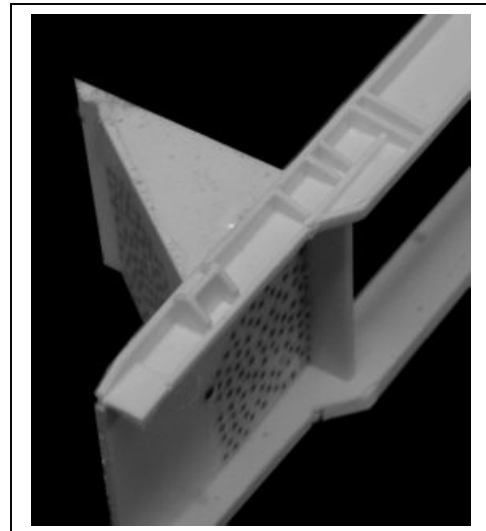

4 The End Unit should be assembled as shown.

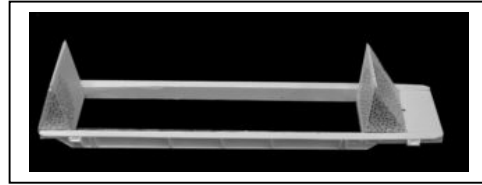

5 Attach the End Unit Fascia (6) to the End Unit Weight (4) as shown.

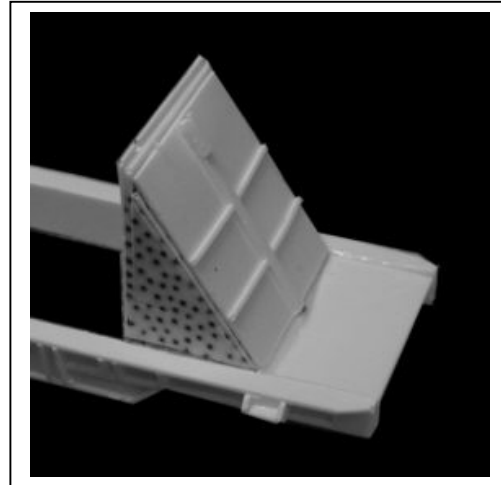

6 Attach the Short End Fascia (7) to the Short End Weight (5) as shown.

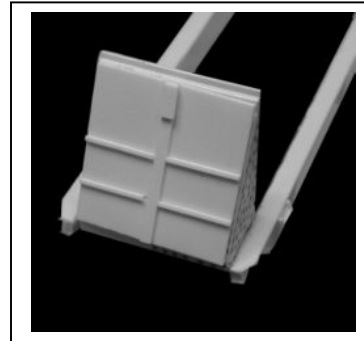

7 Apply the Short End Sides (8) in pairs as shown. The end units also use this same part on the non-coupler end.

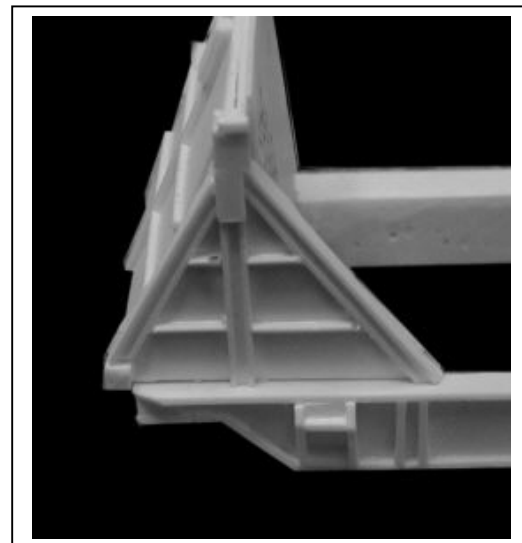

8 End Unit Sides (9) are attached to the coupler end of the end units as shown.

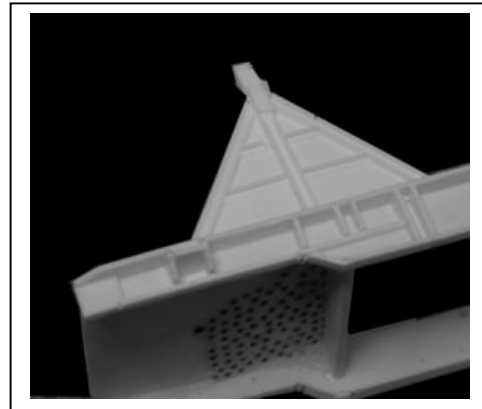

9 All short ends of the units should look like this.



10 Attach the End Sill/Coupler Mount as shown.

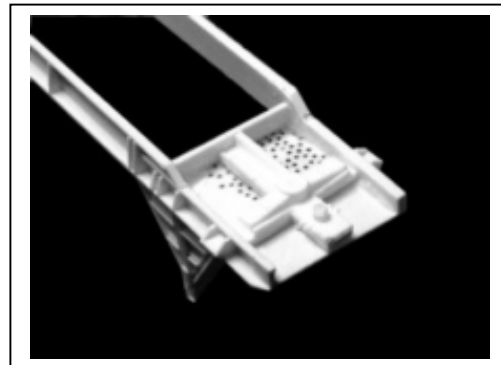

11 Install Male Couplings (16) and Female Couplings (17) alternately on the units.

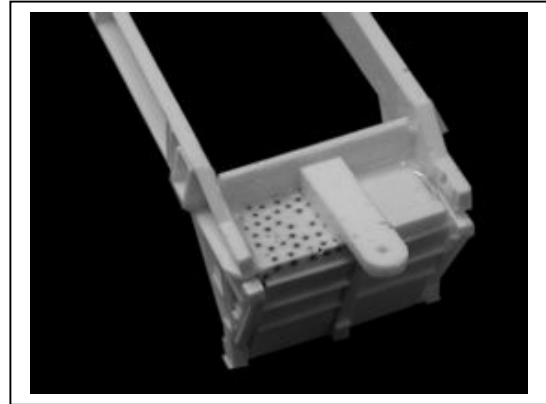

12 The units should mate to each other as shown.

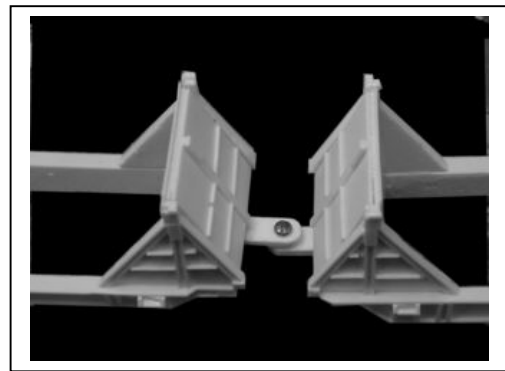

13 Install the End and Center Supports (18,19). These should be glued flush with the bottom of the car. Be sure to sand down any glossy surface to make sure the cement will stick.

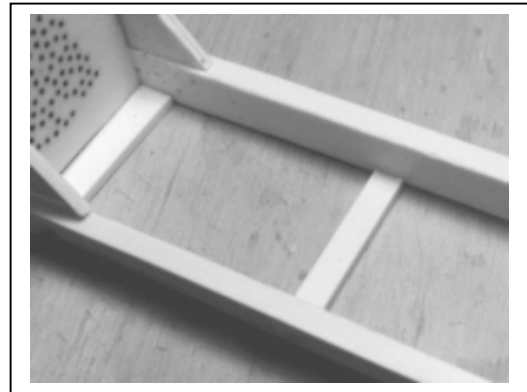

14 Cut a large piece of the netting you purchased from the yard good store. It should be about 3 times the opening of the bottom of the car. Clamp pieces of wood to the netting material as shown. Get it smooth and without wrinkles.

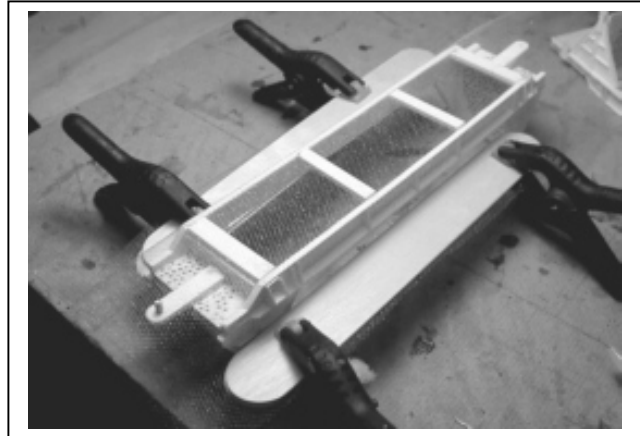

15 Poke wire or files as I did to insure that the netting does not move. Apply ACC cement to the bottom edges of the car where the netting connects. Use “Zip Kicker” or any ACC cement accelerator to set the cement. If you don’t have an accelerator, allow the cement to dry for about an hour. Repair any gaps in the cement now. After the cement has COMPLETELY set, turn the unit over and trim away the excess netting material.

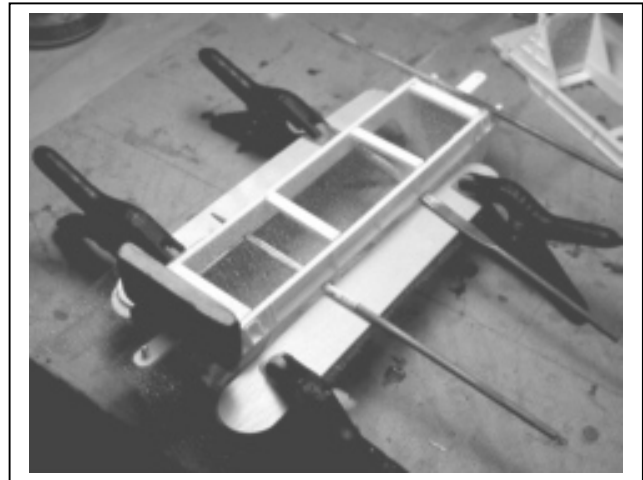

16 Attach the brake reservoir to the end fascia as show. File the brackets so the piping connections will be at the side as shown. Add the brake valve on the 3 units as pictured.

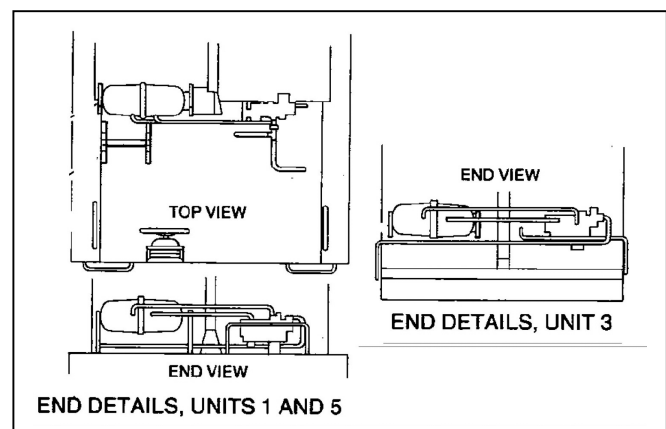

DECALS ARE ATTACHED HERE

PAINTING

- 1) If you followed the instructions for cleaning the parts before assembly, you are ready to paint. A primer such as Floquil's is recommended. Allow to dry overnight before proceeding with any of the color coats.
- 2) Apply a coat of white before painting either yellow or red.

Overcoat entire car with Testor's Glosscoat prior to decaling. After decals have set, apply Testor's Dullcote.

DECALING

The decals provided are a very thin film decal film. Success with these decals depends on following these instructions.

- 1) Cut out the decal segment you are going to apply.
- 2) Dip the decal in warm water which has had 1 drop of DAWN kitchen detergent. Do not leave the decal to soak in the water.
- 3) Slide the decal directly onto the wetted surface with a small brush. Position with the brush. Remove excess water with a tissue.

NOTE: The glue used for the decal sheet is different than what has been used in the past. The water does not dissolve the glue. Water causes a chemical reaction causing an almost immediate release of the decal. For this reason once the decal has been wetted it must be used quickly. It cannot be re-wetted later for use.

- 4) Top coat the decals with Testor's Dullcote for best results.

Decal Layout

