

CONCEPT MODELS

Web Address: <http://www.con-sys.com>
Email: concept_models@con-sys.com

8810 El Toro Way
Stockton, CA

HYDX 701- S SCALE

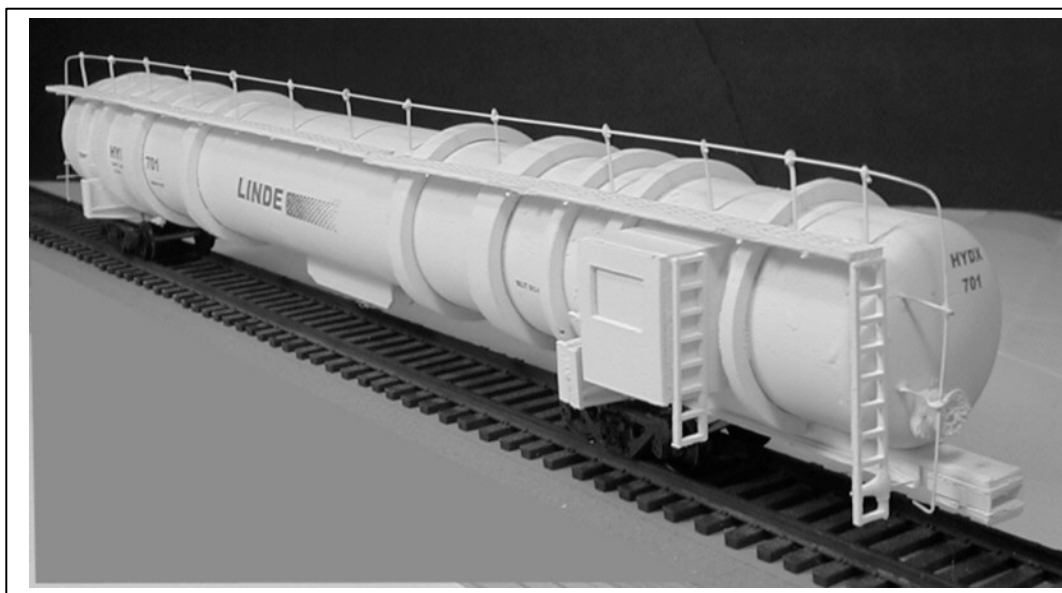
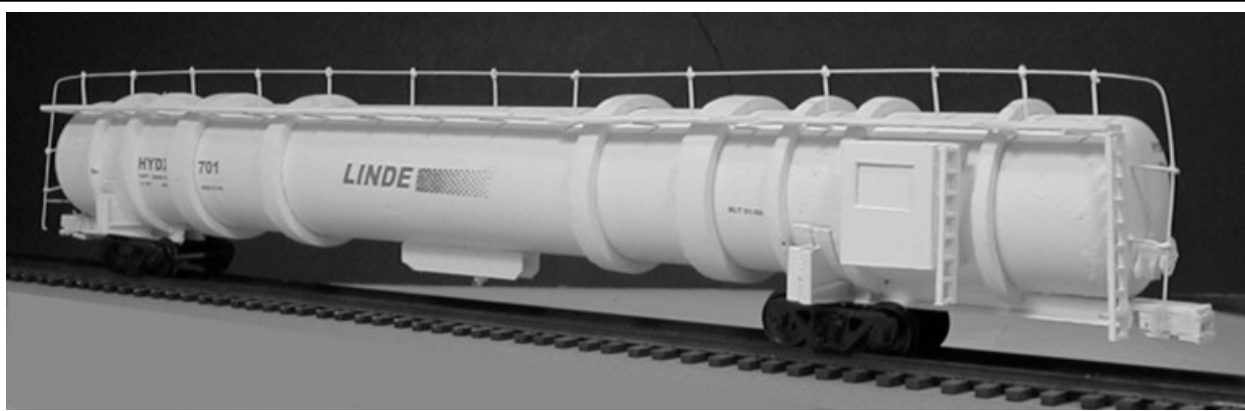

**INSTRUCTIONS FOR LINDE HYDX 701-720
28,000 GAL. TANKER**

PARTS – HYDX 701 28K TANKER

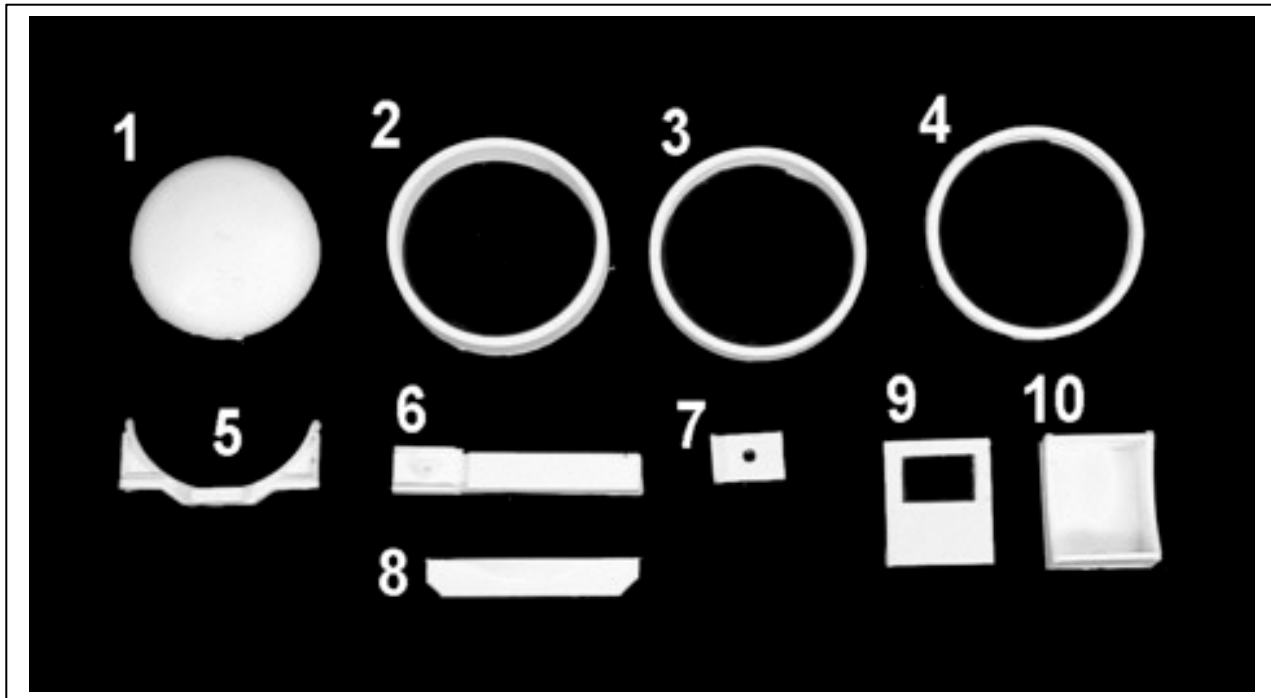

Item No.	PART NO.	DESCRIPTION	QTY.
1	1089	Med.Pressure End – pr	1
2	8531-2	Large Ring (10mm)	2
3	8531-3	Medium Ring (7mm)	2
4	8531-4	Small Ring (3.5mm)	4
5	8531-5	Tank Saddle half	4
6	8531-6	Stub Sill	2
7	8531-7	Coupler Cover	2
8	8531-8	Bottom Ports	1
9	8531-9	Control Cabinet Face	1
10	8531-10	Control Cabinet	1
11	8531-11	Catwalk Section	2

PART NO.	STANDARD PARTS s.f. = scale feet	QTY.
1098	Brake Valve	1
1099	Brake Reservoir	1
1100	Brake Cylinder	1
1102	Brake Wheel Mech.	1
1101	Brake Wheel Mount	1
1103	Brake Wheel	1
1011	Small Pin	1
	PVC Tank Tube – 82 s.f.	1
1104	Placard Holder	4
1105	Placard Mounts	4
1023	Large Pin	12
8531-D	Decals	1
8531-I	Instructions	1

Tools

All basic model workers tools – files, motor-tool with fine burrs & sanding disk, hobby knife, 1/8” drill, #72 drill, #68 drill, 2-56 tap and tap drill, etc.

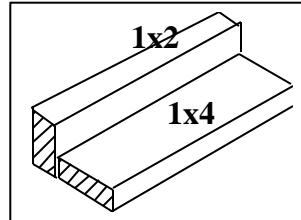

A fixture like this is an aid to drawing the longitudinal lines along the tank of this model

Instructions

NOTE: This kit consists of resin castings and must be assembled with an ACC cement (not provided) – both the thicker types as well as the thin. Solvent cements will **NOT** bond the parts together! Resin parts are more fragile than common styrene plastic used in injection molded models. Use reasonable care in handling and do not apply any solvents. The illustrations at the front show the general layout of parts for the car. Work very carefully when positioning the parts for gluing. ACC cements adhere very quickly and permanently.

Gluing with ACC Cements – USE WITH CARE

ACC cements allow the modeler to work very quickly. A general rule is to use the thin cements to glue long joints taking advantage of capillary action that makes the cement run the length of the seam. The thicker cement is suited to applying large area parts to each other. An accelerator can be applied sparingly. One technique is to apply the glue to one part and the accelerator to the other part to be joined. I also use a Q-tip to apply a minute amount of accelerator to the glue after the parts have been joined. The accelerator triggers the ACC cement to set very quickly. It is only slightly slower with the thicker cement.

WARNING

Some parts may have lead encapsulated within them. In the event the lead is exposed for any reason, do not allow it to remain on the skin. Dispose of any lead shavings that may result. Obey all safety precautions of all suggested cements and assembly materials.

PREPARATION Wash the parts before assembling with a dish washing detergent such as “Dawn”. Rub lightly with a soft sponge.

HYDX 701 PARTS LAYOUT

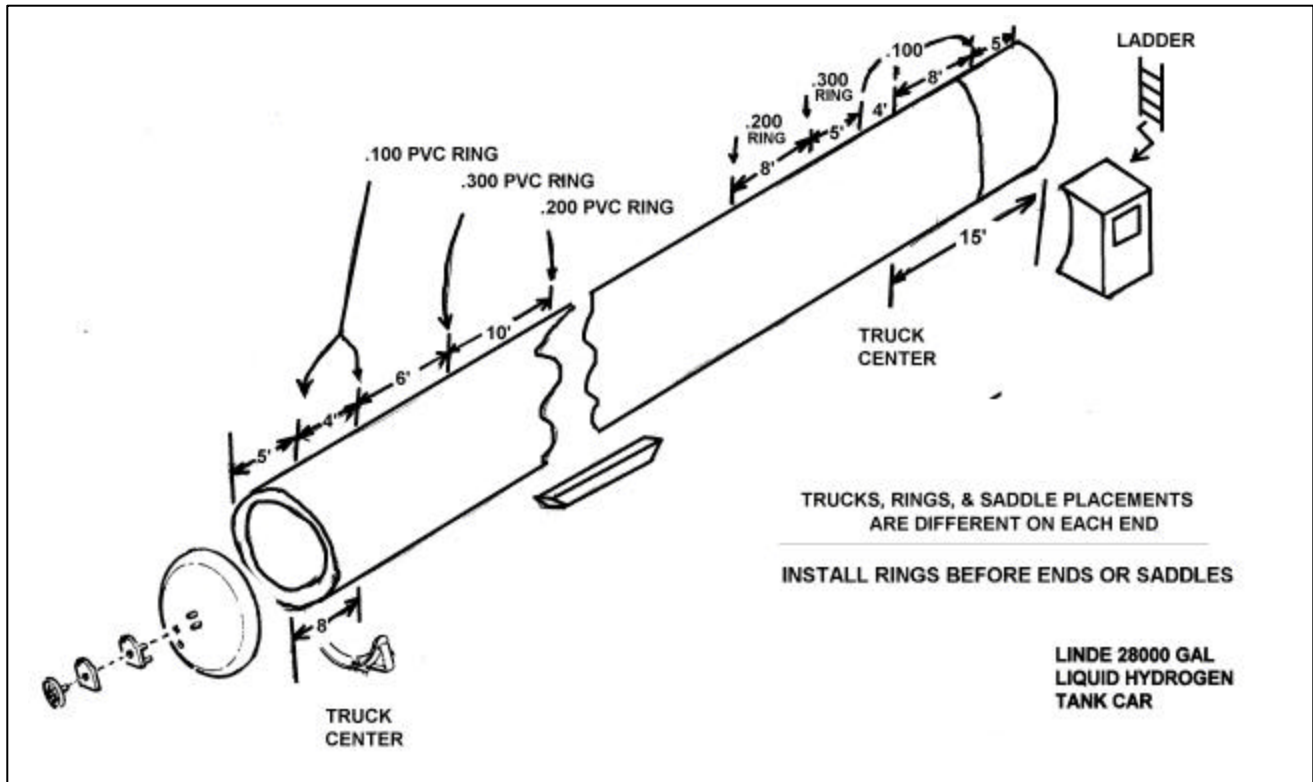

ASSEMBLY

1 Use the template provided to draw longitudinal lines for top and bottom center plus the catwalk location on the tank tube.

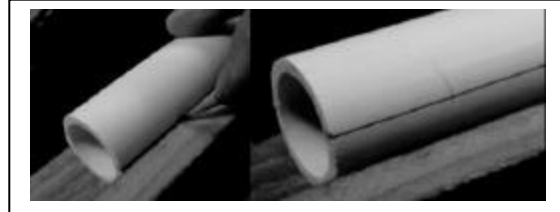

2 Use the layout diagram to position the rings. There are an odd number of rings and the tank layout is not symmetrical. Make sure you apply all rings before adding any other parts. Use ACC cement to hold the rings. Apply a small dot at the top of the ring and allow cement to set or use an accelerator to speed up the process. After you get the rings located, make sure they are straight and fill in the gap between the ring and the tank. The rings are slightly large to compensate for shrinkage of the casting and variations in the tank tube.

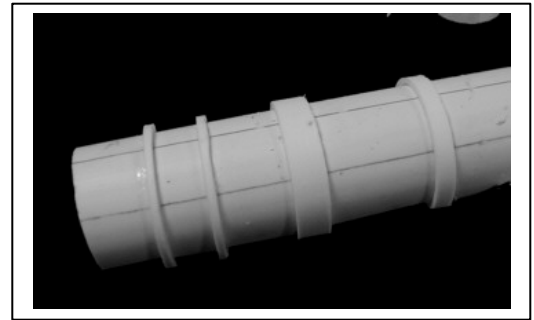

3 Cement the saddle halves together as shown and apply the saddle/bolsters according to the dimensions on the layout diagram. The A and B ends are very different.

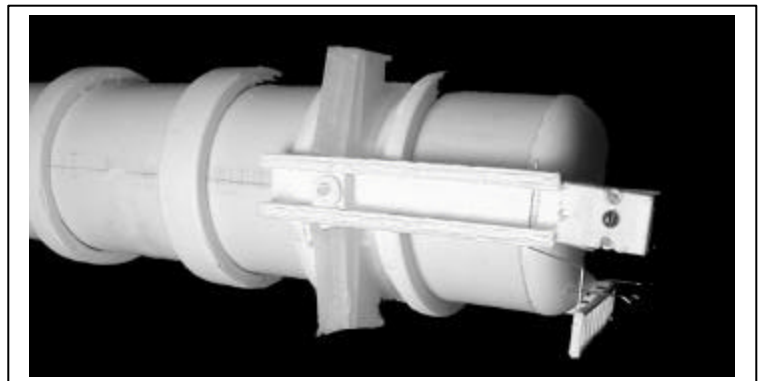
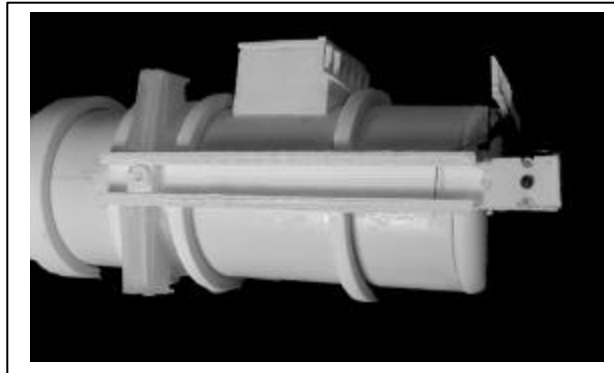

4 Apply the bottom port casting at the center of the tank bottom

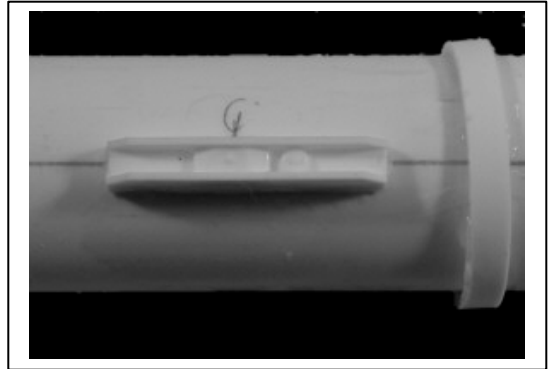

5 Apply the hi-pressure ends to the tank tube.

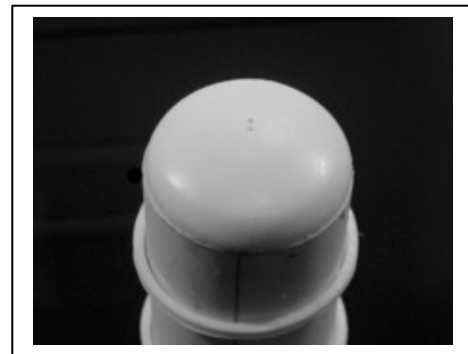

6 Hollow out the control cabinet as shown to allow a window.

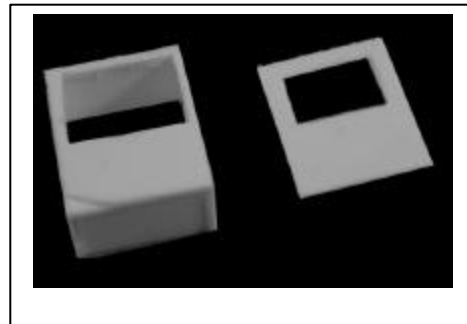

7 Attach the control cabinet to the tank as shown and according to the diagram. The control cabinet face should be tack glued with an adhesive such as Walther's GOO. This will allow the cabinet face to be removed after painting and a clear plastic to be installed as a window (not supplied).



8 Drill #76 holes approximately every 7 scale feet as shown. Common dress pins should be a force fit. Bend the pins level and glue the walkway sections to them. Make the splice of the two sections away from a pin. Trim the ends according to the photo on page one. Use the remaining piece of walkway to make a walkway over the control cabinet. After the walkway is trimmed. Drill holes for Athearn stanchions (not supplied). Drilling should be parallel to the ground to make use of the shape of the stanchions. Use .020" steel music wire for the handrails. Add three ladders as shown on page one.

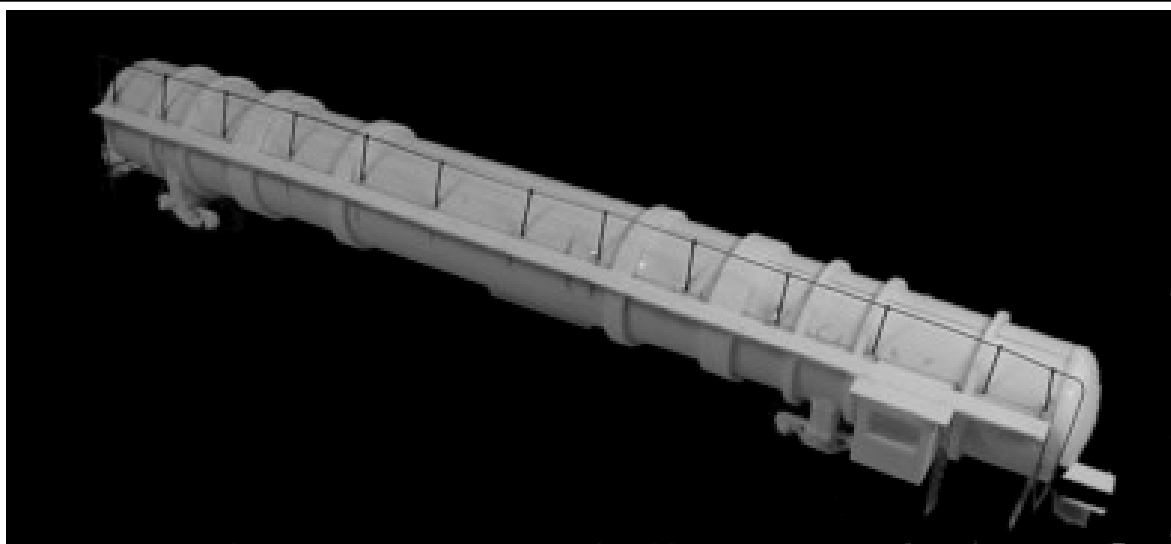
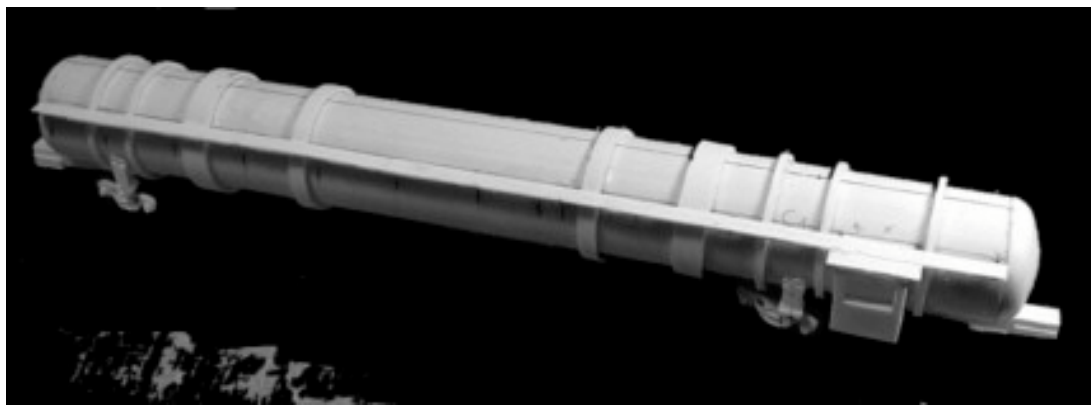
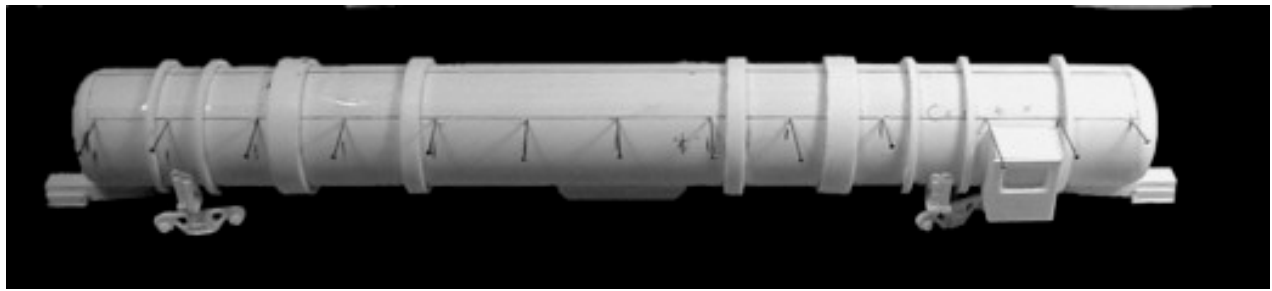

PAINTING

If you followed the instructions for cleaning the parts before assembly, you are ready to paint. A primer is recommended. Allow to dry overnight before proceeding with any color coats. When painting with white do not over dilute with thinner.

Now that Floquil has left the scene I'm buying ACE hardware's enamel part of their rust proof line. A half pint goes a long way. Two coats of white gloss with plenty of drying time in between is recommended.

If you didn't use gloss paint, overcoat entire car with Testor's Glosscote prior to decaling. If you decal over the Glosscote as soon as it is just dry to the touch, decal adhesion is improved.

DECALING

The decals provided are a very thin film decal film. Success with these decals depends on following these instructions.

- 1) Cut out the decal segment you are going to apply with a SISSORS.
- 2) Dip the decal in warm water which has had 1 drop of DAWN kitchen detergent. Do not leave the decal to soak in the water.
- 3) Slide the decal directly onto the wetted surface with a small brush. Position with the brush. Remove excess water with a tissue.

NOTE: The glue used for the decal sheet is different than what has been used in the past. The water does not dissolve the glue. Water causes a chemical reaction causing an almost immediate release of the decal. For this reason once the decal has been wetted it must be used quickly. It cannot be re-wetted later for use.

- 4) Top coat the decals with Testor's Dullcote for best results.

