

CONCEPT MODELS

Web Address: <http://www.con-sys.com>
Email: concept_models@con-sys.com

8331 Sheep Ranch Rd.
Mountain Ranch, CA 95246



**INSTRUCTIONS FOR PRODUCT:
ACFX 89352 8-AXLE "WHALE" TANK CAR**

ACFX 89352 PARTS

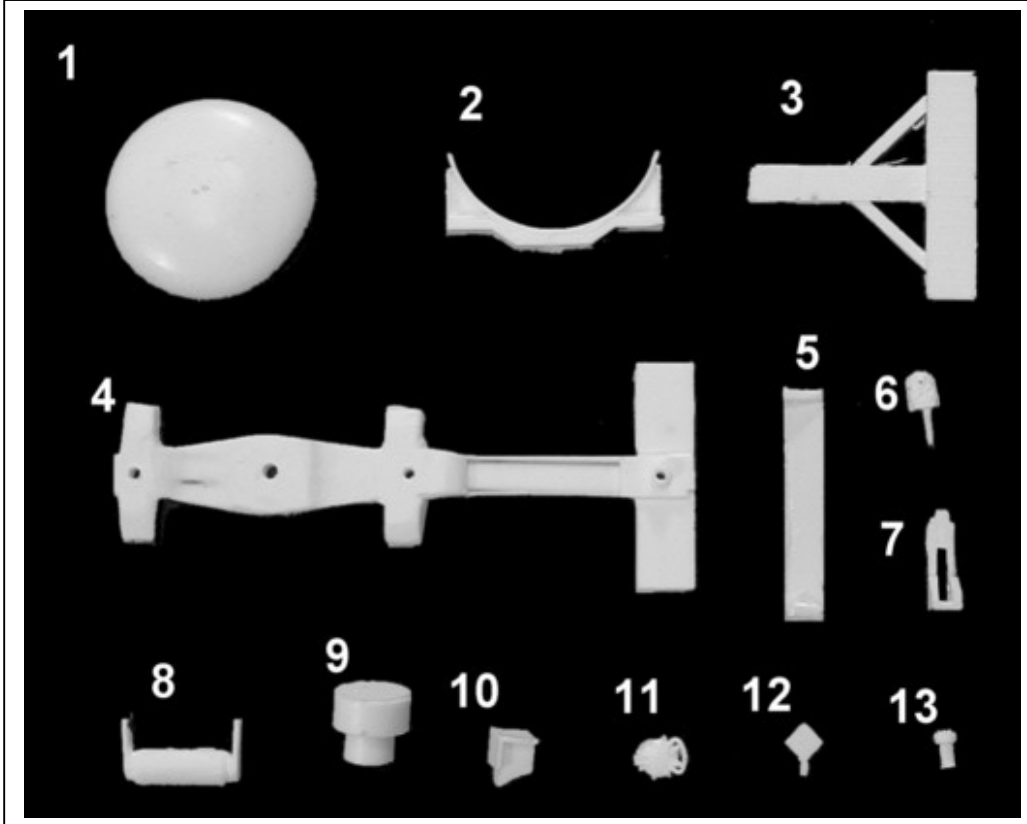

Item No.	Part No.	DESCRIPTION	QT Y.
1	8038-1	Tank Car Ends – Non-pressure	(pr)
2	8038-2	Tank Bolsters	2
3	8038-3	Truck Bolster Top	2
4	8038-4	Truck Bolster Bottom	2
5	8038-5	Tank Platform	2
6	8038-6	Brake Wheel Mechanism	1
7	8038-7	Brake Stand	1
8	8038-8	Aux. Brake Reservoir – med.	1
9	8038-9	Housing – Small	1
10	8038-10	Brake Valve Bracket	1
11	8038-11	Manway	1
12	8038-12	Placard	4
13	8038-13	Bottom Valve	1
14	8038-14	Stuffing Box Handle	1

DESCRIPTION	QT Y.
2-56 x 1/8" Screws	2
2-56 x 3/8" Screws	2
Coupler Pocket Covers	2
Brake Valve	1
Brake Cylinder	1
Brake Wheel	1
Small Pin	1
82 s.f. Tank Tube	1
Tank Template	1
Decals	1
Instructions	1

Tools and Things You Will Need

All basic model workers tools – files, motor-tool with fine burrs, hobby knife, Wood blocks for holding parts square for scribing, metal square with center finder is a nicety, etc. The following drills are useful: #76, #72, #61, and #50. A 2-56 tap is also required to tap the Tank Bolsters.

.020” music wire for handrails.

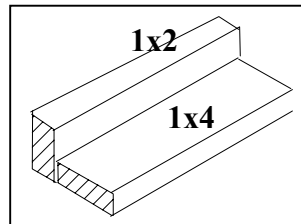

A gluing fixture is a great aid to assembly. It helps hold parts square while gluing or scribing.

Instructions

NOTE: This kit consists of resin castings and must be assembled with an ACC cement (not provided) – both the thicker types as well as the thin. Solvent cements will **NOT** bond the parts together! Resin parts are more fragile than common styrene plastic used in injection molded models. Use reasonable care in handling and do not apply any solvents. The illustrations at the front show the general layout of parts for the car. Work very carefully when positioning the parts for gluing. ACC cements adhere very quickly and permanently.

Gluing with ACC Cements – USE WITH CARE

ACC cements allow the modeler to work very quickly. A general rule is to use the thin cements to glue long joints taking advantage of capillary action that makes the cement run the length of the seam. The thicker cement is suited to applying large area parts to each other. An accelerator can be applied sparingly. One technique is to apply the glue to one part and the accelerator to the other part to be joined. I also use a Q-tip to apply a minute amount of accelerator to the glue after the parts have been joined. The accelerator triggers the ACC cement to set very quickly. It is only slightly slower with the thicker cement.

WARNING

Some parts have lead encapsulated within them. In the event the lead is exposed for any reason, do not allow it to remain on the skin. Dispose of any lead shavings that may result. Obey all safety precautions of all suggested cements and assembly materials.

PREPARATION Wash the parts before assembling with a dish washing detergent such as “Dawn”. Rub lightly with a soft sponge.

ASSEMBLY

1 Clean the entire Main Tank Tube with lacquer thinner. Work fast since the chemicals can soften the PVC if left on for a long time. The idea is to remove the printed markings and take off the gloss surface. Draw a line the entire length of the tube using a straight edge as shown. Transfer the position of the line as shown and draw a second line 180 degrees from the first. This provides a center line top and bottom of the tank tube.

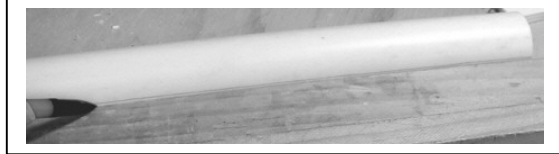

2 Use the provided template to install the tank bolsters. Make sure the part is straight (perpendicular to the tube length).



3 NOTE: There is an "A" end and a "B" end and mark in pencil. Refer to the tank layout template. Cement the Tank Pressure Ends (1) to the tank tube.

4 Install the Brake Valve Bracket (10) and the Brake Reservoir (8). The Brake Valve Bracket should be filed down to fit the contour of the tank. The Brake Reservoir mounts need to be filed to make the brackets to appear attached to the bottom of the tank.



5 Cut out the extra tank component diagram and attach to the tank tube temporarily. Drill 4 #60 or #61 holes at the four corners of the railing, Drill 4 #76 holes near the centers of the railings. Remove the template.

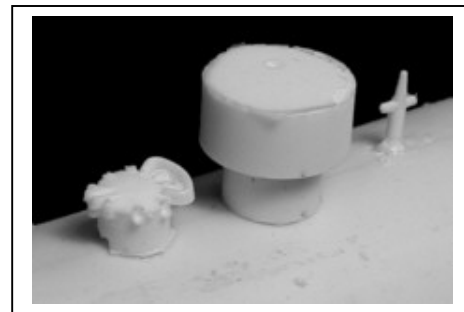
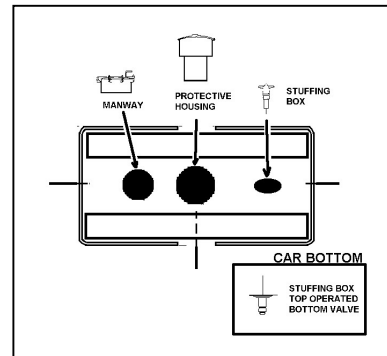

6 Install the Manway (11), Protective Housing (9), and the Stuffing Box Handle in the positions as shown. Add the Tank Platforms (5) making sure they are inside of the railing mounting hole patterns.

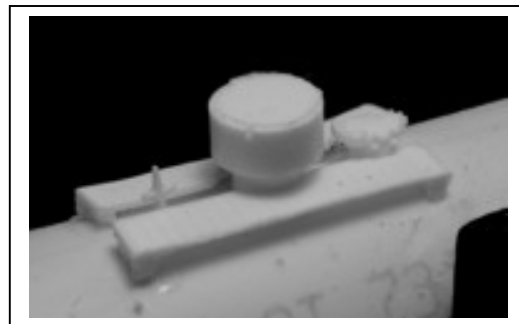

7 Use another of the railing patterns as shown for a bending jig. You will only need to add the three nails on the left to bend the railings. Use .020" music wire for the railings. (not supplied) Use 4 Athearn long stanchions at the corners of the railings. (not supplied)

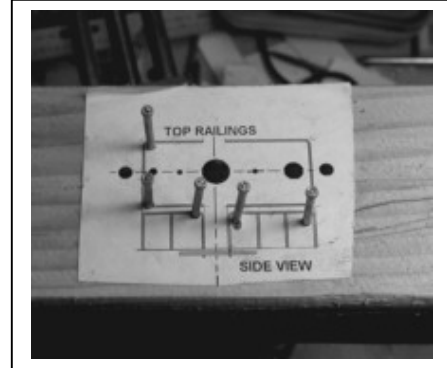

8 Install the handrails as shown. Use ACC cement to keep everything in place including where the stanchions intersect the handrails.

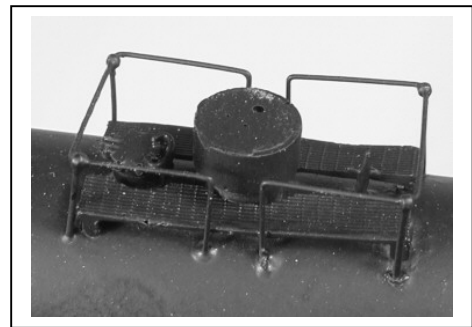

9 Install the guard rail with the Guard Rail Stanchions as shown. Thread 6 stanchions on a 82' (s.f.) piece of .020" music wire to make the guard rails. Attach the music wire to the bottom corner of the Tank Bolsters. Glue the Guard Rail Stanchions in place according to the Tank Template. Add the end stanchions.

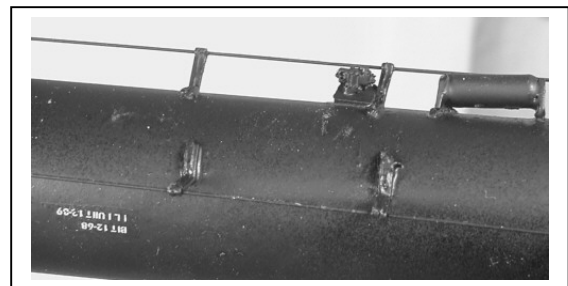

10 Glue the Truck Bolster Top (3) to the Truck Bolster Bottom (4).

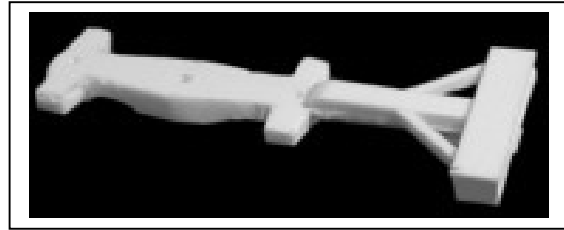

11 Glue the Brake Wheel Mechanism (6) to the Brake Stand (7) as shown. Use the small pin to attach the brake wheel, then trim off the excess length of the pin. Drill #76 holes at the ends of the Bolster Top and add .020 music wire handrail

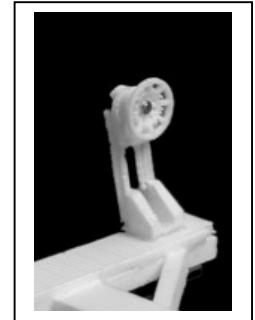
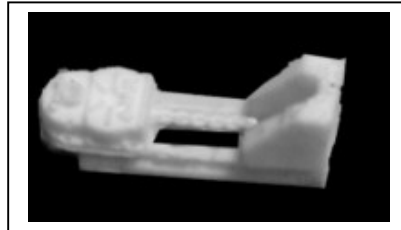

12 After painting the trucks will be installed and the assembly will be installed using the 3/8" screw after drilling and tapping the Tank Bolsters (2) for 2-56 threads.

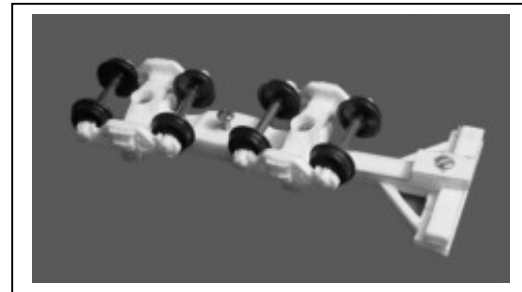

ACFX 89352
CAPY 43800 GALS

CM MARK 00 12FT GR
WABCO PAC BR 13M
SPRING D-3
CH36" IW STL WHLS
SE67CIE CPLR

ACFX 89352 TANK
C
LD LMT 394000
LT WT 131000

HERIBESITE P-103
LINED 2-02
BUN LYN

BLT 12-08
RE-BUILT 12-09

SAFETY VENT 70 LBS.
TANK 100 LBS.
TESTED 05 01 78
AT MULTER PA.
XX LER

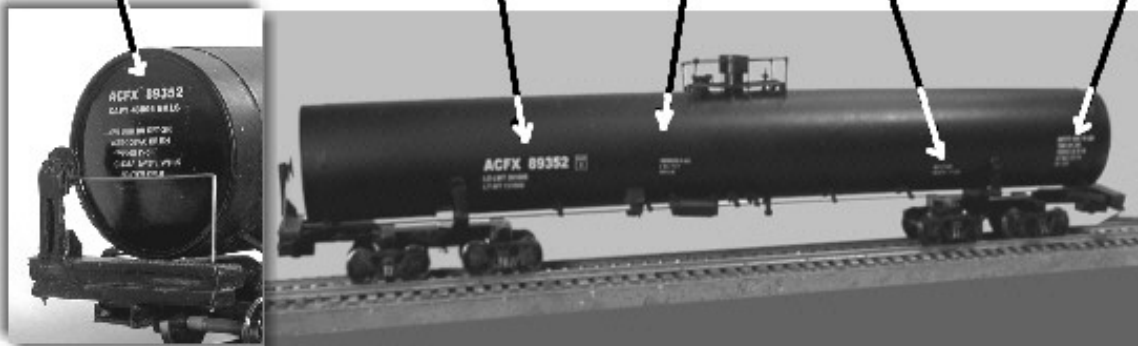

PAINTING

. Use a lacquer based primer such as floquil.

- 1) If you followed the instructions for cleaning the parts before assembly, you are ready to paint. A primer such as Floquil's is recommended. Allow to dry overnight before proceeding with any of the color coats.

Overcoat entire car with Testor's Glosscoat prior to decaling.

DECALING

The decals provided are a very thin film decal film. Success with these decals depends on following these instructions.

- 1) Cut out the decal segment you are going to apply.
- 2) Dip the decal in warm water which has had 1 drop of DAWN kitchen detergent. Do not leave the decal to soak in the water.
- 3) Slide the decal directly onto the wetted surface with a small brush. Position with the brush. Remove excess water with a tissue.

NOTE: The glue used for the decal sheet is different than what has been used in the past. The water does not dissolve the glue. Water causes a chemical reaction causing an almost immediate release of the decal. For this reason once the decal has been wetted it must be used quickly. It cannot be re-wetted later for use.

- 4) Top coat the decals with Testor's Dullcote for best results.